

HP SERIES DOCK LEVELER HYDRAULIC SPECIFICATIONS



Design Highlights

- Exclusive SafeTFrame™ Design
- Lug Style Lip Hinge & Lambda™ Beam Structure
- GRAVITY LIP™ Mechanical Lip Extension
- T.E.N.V. Pump/Motor Assembly & Regenerative Hydraulics
- Nema 4X Push-button Control Panel (Non-Interlock Capable)
- Single Phase or Three Phase Power
- Hydraulic Velocity Fuse Safety Stop
- Open Subframe Design
- Automatic Retracting 60,000 lbs. (27,215 Kg) Structural Dock Level Support Legs
- Full Operating Range Toe Guards
- Below-dock Endloading Capability
- 16" Lip Standard (406 mm)
- Fixed Rear Hinge - No Pinch Points
- Integral Maintenance Strut & Lip Support Latch
- Heavy-duty B410-14F Dock Bumpers
- Reduce Lip Crown/Extended Lip Chamfer

Project Information

Job Name _____
 Address _____
 General Contractor _____
 Distributor _____
 Model _____ Quantity _____ Voltage/Phase _____

Certified For Construction

By _____
 Company _____
 Address _____
 Date _____

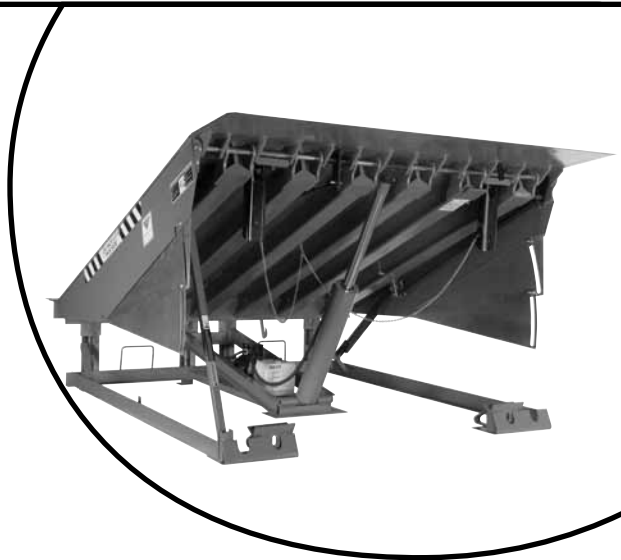

Available Options

- Non-Metallic Control Panel (Interlock Capable)
- HP Option 1 Package:
 - Automatic Return -to-Dock
 - Non-Metallic Control Panel (Interlock Capable)
- Brush Weatherseal
- ENERGY GUARD® Perimeter Weatherseal System
- 18" Lip (457 mm)
- 20" Lip (508 mm)
- 24" Pit Conversion (607 mm)
- Spray Foam Insulated Deck
- Abrasive Surface
- Spray Metalize (Deck, Lip & Subframe)
- Special Paint Color
- Lip Taper _____ (specify)
- High Lip Crown
- Pan Option:
 - For installation without preformed concrete pits, dock leveler supplied with integral pre-formed steel pan for pour-in-place construction. Dock leveler shall be in an enclosed steel pan structure complete with its own six-piece welded structural curb angles and concrete anchors. The dock leveler is to be concreted in place as the floor is poured.
- Other _____



Pan Option

Accessories

- STAR® Vehicle Restraint _____
- HIDDEN HOOK™ Recessed Restraint
- MANUAL SURFACE CHOCK Wheel Restraint
- SURFACE CHOCK™ Wheel Restraint
- AUTO CHOCK® Wheel Restraint
- Master or Combo Control Panel _____

Bumper Options

- B410-14 VB420-11F
- B610-14 VB420-11 Steel Faced
- B610-14F Other _____

Capacity

- 30K lb (13.6K kg) 45K lb (20.4K kg)
- 35K lb (15.8K kg) 50K lb (22.7K kg)
- 40K lb (18K kg)

HP SERIES DOCK LEVELER HYDRAULIC SPECIFICATIONS

1. General: "HP" series dock leveler to be complete package, including unitized motor and pump assembly, integral support strut and lip lock, full operating range toe guards, and two heavy-duty dock bumpers as standard. Unit conforms to ANSI/MH14.1-1987 performance requirements. Unit to be manufactured by Kelley.

2. Construction, Platform Assembly: Platform to be constructed of unitized, robotically welded high tensile steel safety tread deck plate. Exclusive Lambda deck beams optimize twist resistance and stress distribution. Deck to be ¼" (6.3 mm) thick on 30K-35K lb. (13.6K-15.8K kg), and ⅝" (7.9 mm) thick on 40K-50K lb. (18K-22.7K kg) capacities.

3. Lip Assembly: Lip to be ⅝" (16 mm) thick on 30K-35K lb. (13.6K-15.8K kg) capacities, and 1¼" (17.5 mm) on 40K-50K lb. (18K-22.7K kg) capacities. Self-cleaning lug-style lip hinge. All units to be 16" (406 mm) high tensile steel safety tread lip plate with chamfered leading edge. Lip rod to be a minimum of 1" (25 mm) solid steel on all capacities.

4. Lip Extension: Automatic lip extension ensures proper lip extension with descent of dock leveler into trailer. Auxiliary leg release to allow lowering of dock leveler below-dock level without extending lip.

5. Rear Subframe & Hinge: Rear structural frame consists of a welded structure constructed from 4 structural angle vertical members connecting two horizontal members. The upper rear angle has longitudinal support gussets & additional deck supports to promote structural stiffness. The hinge system consists of four ¾" (19 mm) thick lugs allowing 4 inches (102 mm) of side to side deck twist.

6. SafeTFrame™: Adjustable front and rear leveling system eliminates the need for installer to place and weld steel shim stock under the vertical uprights. System provides more consistent installation and prevents a gap or "bump" between the rear transition angle and curb angle. The rear SafeTFrame system consists of four heavy-duty vertical uprights at the rear of the leveler, each with an adjustable 3"x3" (76mm x 76mm) pad that sits on the pit floor. Front SafeTFrame system includes an adjustment point on each front support pedestal accessed through the open lip hinge area. Both front pedestals and rear supports can be micro-adjusted independently through a 1 ½" (38 mm) range using a ½" (12.7 mm) socket, compensating for even the worst pit conditions.

7. Power Unit: Power unit is an electric hydraulic pump and valve assembly (remote mounting available).

8. Electrical: Available in 120/208/240V single-phase or 208/240/480/575V three phase. Electrical system to include motor overload protection as standard. Power unit is mounted to unit subframe (elevated off pit floor).

9. Hydraulic: Main cylinder minimum 4" (101 mm) diameter bore. All weather hydraulic fluid with viscosity of 15 cSt at 40°C (100°F). Totally enclosed non-ventilated hydraulic pump and motor assembly with single hose to cylinder for longer life and lower maintenance costs.

10. Control Panel: Heavy-duty, single push-button activation. Optional A.R.T.D. and interlocking with other dock equipment available for added safety.

11. Product Finish: Enamel green finish.

12. Safety Legs: Automatic 60,000 lbs. (27,215 kg) structural dock level support legs. Drop tested to the full rated capacity of the dock leveler.

13. Toe Guard Protection: Full operating range toe guards with two galvanized sliding guards (yellow OSHA required markings per ANSI/Z535.1) provided on the sides of the dock leveler.

14. Integral Support Strut & Lip Lock: A permanently mounted support strut and lip lock are provided to support the lip and leveler during routine maintenance and pit cleaning.

15. Float Compensation: Allows for vertical carrier deflection when lip is in contact with truck bed.

16. Operation: Kelley's "HP" hydraulic dock leveler platform to be operated by hydraulic cylinder controlled by a remote push-button station. To operate dock leveler, dock attendant presses "RAISE" button, dock leveler raises. When button is released, dock leveler descends under gravity to truck bed and lip automatically extends. The unit then floats with truck movement. To restore dock leveler, dock attendant presses "RAISE" button. As deck raises, lip moves pendent and dock leveler is stored. Dock leveler can be lowered to fully supported below-dock position, without extending lip, to service low trucks in end load situations. 6' (1.83 m) and 8' (2.4 m) long models to have 12" (305 mm) above and 12" (305 mm) below-dock working range. Standard working range on 10' (3.05 m) long units is 18" (457 mm) above-dock and 12" (305 mm) below-dock.

17. Installation: Unit shipped completely assembled, and ready for installation in pre-formed concrete pit. Pit depth is 20" (508 mm) for 6' (1.83 m) and 8' (2.4 m) long units, 24" (607 mm) for 10' (3.05 m) long units. Pit construction to be in accordance with certified Kelley pit detail drawings. Contact Kelley for current cost and nearest distributor.

18. Limited Warranty: Limited 1-year parts and labor base warranty with an additional limited 4-years parts only warranty on hydraulic power unit and cylinder. Limited 10-year structural warranty available upon engineering approval of written application.

19. Bumpers: Unit to include two heavy-duty dock bumpers model B410-14F (4" Thick x 14"W x 10"H) (102 mm x 356 mm x 254 mm).

NOMINAL DIMENSIONS

MODEL	WIDTH	LENGTH
HP6X6	6' (1.83 m)	6' (1.83 m)
HP6.5X6	6'6" (2.01 m)	6' (1.83 m)
HP7X6	7' (2.13 m)	6' (1.83 m)
HP6X8	6' (1.83 m)	8' (2.44 m)
HP6.5X8	6'6" (2.01 m)	8' (2.44 m)
HP7X8	7' (2.13 m)	8' (2.44 m)
HP6X10	6' (1.83 m)	10' (3.05 m)
HP6.5X10	6'6" (2.01 m)	10' (3.05 m)
HP7X10	7' (2.13 m)	10' (3.05 m)

