

VERSADOCK™ SERIES DOCK LEVELERS

H Y D R A U L I C S P E C I F I C A T I O N S

Design Highlights

- Full 9' Wide Below-dock Access
- Integrated Steel Faced Vertical Bumpers
- Standard 60,000 lbs. (27,215 kg) Capacity Design
- Below-dock Endloading Capability
- Regenerative Hydraulics
- Automatic Return-to-Dock
- Independent Hydraulic Lip Control (Quick Cycle)
- Mushroom-style Stop Button
- Steel NEMA 12 Push-button Control Panel (Interlock Capable)
- Hydraulic Velocity Fuse Safety Stop
- Dual Integral Maintenance Struts & Lip Support Latch
- Weatherseal
- Heavy-duty Steel Faced Dock Bumpers
- Standard 18" Lip (457 mm)
- Reduced Lip Crown/Extended Lip Chamfer

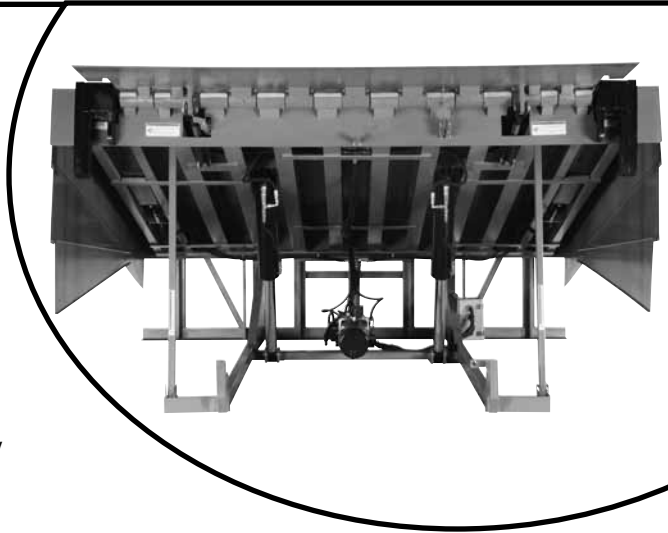

Available Options

- 20" Lip (508 mm)
- ENERGY GUARD® Perimeter Weatherseal System
- Safety Barrier Lip
- Special Paint Color
- Pit Steel
- High Lip Crown
- Lip Taper _____ (specify)
- Other _____

Accessories

- STAR® Vehicle Restraint _____
- HIDDEN HOOK™ Recessed Restraint
- SURFACE CHOCK™ Wheel Restraint
- AUTO CHOCK® Wheel Restraint
- Master or Combo Control Panel _____

Capacity

- 60K lb. (27.2K kg)

Project Information

Job Name _____
 Address _____
 General Contractor _____
 Distributor _____
 Model _____ Quantity _____
 Voltage/Phase _____

Certified For Construction

By _____
 Company _____
 Address _____
 Date _____



VERSADOCK™ SERIES DOCK LEVELERS

HYDRAULIC SPECIFICATIONS

NOMINAL DIMENSIONS							
MODEL	LEVELER WIDTH	LEVELER LENGTH	LIP SIZE	(BELOW-DOCK) RANGE	(ABOVE-DOCK) RANGE	PIT WIDTH	PIT DEPTH
VERSA12900	9' (2.75 m)	12' (3.66 m)	20" (508 mm)	18" (457 mm)	12" (300 mm)	9' (2.75 m)	32" (812 mm)
VERSA10900	9' (2.75 m)	10' (3.05 m)	18" (457 mm)	15" (381 mm)	12" (300 mm)	9' (2.75 m)	29" (737 mm)
VERSA8900	9' (2.75 m)	8' (2.44 m)	16" (406 mm)	12" (300 mm)	12" (300 mm)	9' (2.75 m)	26" (662 mm)

- 1. General:** “VERSADOCK” series hinged lip dock leveler with hydraulic operated platform and hydraulic lip extension. Unit conforms to ANSI/MH14.1-1987 performance requirements. Unit to be manufactured by Kelley, with standard 60,000 lbs. (27,215 kg) capacity.
- 2. Construction, Platform Assembly:** Platform constructed of high tensile steel safety tread deck plate supported by channel beam design construction. Structural members fully welded to front header. Deck to be a minimum of $\frac{3}{8}$ " (9.5 mm). I-beam deck construction.
- 3. Lip Assembly:** All units to be high tensile steel safety tread lip plate with chamfered leading edge. Lip to be $\frac{3}{4}$ " (19 mm) thick. Front hinge to have full width structural front header and heavy wall tubing with a minimum of $\frac{3}{4}$ " (19 mm) wall thickness. Front hinge shaft is to be a minimum of $1\text{-}\frac{1}{4}$ " (31.3 mm) solid steel. See model listing for length of lip.
- 4. Rear Subframe & Hinge:** Rear structural frame consists of seven (7) vertically supported rear hinges.
- 5. Power Unit:** Power unit consists of an electric hydraulic pump and valve assemblies (can be remote mounted).
- 6. Electrical:** Motor is 1 h.p., NEMA Standard T.E.N.V./56C frame. Standard motor voltages available are 120/208/240V single phase or 208/240/480V and 575V three phase. RPM: 3450. Electrical system has built-in motor overload protection as standard. Power unit is mounted to unit subframe (elevated off pit floor) and pre-wired to an integral junction box. (See recommended wire size reference guide for installation).
- 7. Hydraulic:** Dock leveler to have dual 4" (101.6 mm) lifting cylinders and dual 2.5" (64 mm) lip cylinders. Adjustable bumpers supported by cylinders with a minimum 2- $\frac{1}{2}$ " (64 mm) diameter bore. All weather hydraulic fluid with viscosity of 15 cSt at 40°C (100° F).
- 8. Control Panel:** Steel interlock capable control panel with motor starter, thermal overload, control circuit breaker with reset capability. Separate control buttons shall be furnished for lip extension, dock leveler raise and mushroom-style stop as standard.
- 9. Product Finish:** Waterborne air dry direct to metal enamel green paint.
- 10. Open Subframe Design:** Front sub-frame is open to provide for easy clean out and maintenance.
- 11. “Nite-Lock”:** Permanent “Nite-Lock” to prevent unauthorized entry beneath locked overhead door is standard.
- 12. Toe Guard Protection:** Full operating range toe guard protection is provided on the sides of the leveler. Yellow OSHA required markings IAW ANSI Z535.1 provided on the sides of the dock leveler.
- 13. Dual Integral Maintenance Strut & Lip Support Latch:** Two permanently mounted hinged, lockout capable integral maintenance strut & lip support latch are provided to support the lip section and leveler during maintenance.
- 14. Grease Fittings:** Grease fittings standard on lip hinge.
- 15. Weatherseal:** Brush weatherseal standard on leveler sides.
- 16. Mushroom-style Stop Button:** Stops the leveler instantly when depressed. The “STOP” button is maintained contact type which activates a solenoid on the leveler hydraulic system. The dock attendant does not have to continuously hold the stop button to maintain the leveler in a “STOP” position.
- 17. Quick Cycle Lip Extend:** Properly sized cylinders and the “LIP EXTEND” button ensure quickest leveler cycle time by not having to fully raise the leveler before extending the lip onto the truck bed.
- 18. Below-dock Control (Endloading):** Push-button controlled feature extending lip beyond lip supports for below-dock endloads.
- 19. Auto Return-to-Dock:** Solid state proximity switch senses when truck has departed via position of lip and automatically restores leveler to dock level storage position.
- 20. Out of Level Compensation:** Leveler platform is designed to compensate for canted truck beds up to 4" (101.6 mm) side to side.
- 21. Float Compensation:** Allows for vertical carrier deflection when lip is in contact with truck bed.
- 22. Operation:** The VERSADOCK Hydraulic Dock Leveler shall be supplied complete with platform, lip, retractable bumpers and power unit, including motor, pump and valve assembly. VERSADOCK to have complete hydraulic control of all functions. Platform, lip and retractable bumpers to be operated by independent hydraulic cylinders controlled by a remote push-button station. To operate leveler, dock attendant presses the leveler “RAISE” button, the bumpers retract and the leveler raises and lip extends hydraulically. When button is released, leveler descends under gravity to truck bed and the bumpers extend until contact with the aft end of the trailer. The leveler then floats with truck movement. To restore leveler, dock attendant presses leveler “RAISE” button or when truck departs, the leveler descends under hydraulic control and automatically restores to cross traffic position. The “LIP EXTEND” button will extend the lip at any point in the leveler cycle. Pushing the mushroom-style “STOP” button allows the dock attendant to immediately stop the leveler when necessary. Pulling out the “STOP” button allows the leveler to operate again. Standard below-dock level operation allows for below-dock endloading with push-button control.
- 23. Installation:** Dock leveler shipped complete and ready for installation. Pit construction to be in accordance with certified Kelley pit detail drawings. Control panel is furnished for remote mounting and electrically interconnected by others. Contact Kelley for current cost and nearest distributor.
- 24. Limited Warranty:** Warrants all components to be free of defects in material and workmanship, under normal use, for a 1-year base period from date of shipment in accordance with Kelley Standard Warranty Policy. The “Base Warranty Period” will begin on the completion of installation or the sixtieth (60th) day after shipment, whichever is earlier. Additional limited 4-year parts only warranty on hydraulic power unit and cylinders. Limited prorated 10-year structural warranty available upon engineering approval of written application.
- 25. Bumpers:** Unit to include two integrated steel faced bumpers.



Integrated Steel Faced Bumpers

KELLEY