



# FOAM DOCK SEAL WITH HEAD CURTAIN

D S H S E R I E S S P E C I F I C A T I O N S

## Design Highlights

- Top of Hood is Tapered Forward and Securely Fastened to the Building Wall
- Tapered Top is Supported with Thick Wall Aluminum Pipe
- Fiberglass Stays Add Stiffness to Hood Top to Prevent Sagging
- Hood Curtain Splits Offer Load Relief and Higher Clearance
- Roll-formed galvanized steel framing reduces pressure on building wall
- Endurance Tested Foam Core is Continuously Bonded to Frame Surface with Flexible, Nonflammable adhesive
- A Wide Selection of Durable Coated Fabrics Provide Maximum Durability
- Highly Resilient, Open-Cell Polyurethane Foam Keeps Original Shape and Compresses Easily to Extend Seal Life
- Side Pad Bottoms are Tapered to Avoid Pinching and Wear
- All Pads are Vented for Air and Moisture Release
- Full Length Yellow Stripes Guide Drivers to the Dock
- Heavy-Duty, Galvanized Steel Mounting Brackets Included

## Project Information

Job Name \_\_\_\_\_  
 Address \_\_\_\_\_  
 General Contractor \_\_\_\_\_  
 Distributor \_\_\_\_\_  
 Quantity \_\_\_\_\_

## Certified For Construction

By \_\_\_\_\_  
 Company \_\_\_\_\_  
 Address \_\_\_\_\_  
 Date \_\_\_\_\_



# FOAM DOCK SEAL WITH HEAD CURTAIN

## DSH SERIES SPECIFICATIONS

### APPLICATION DATA

Door Width: \_\_\_\_\_ ft. \_\_\_\_\_ in.  
 Door Height: \_\_\_\_\_ ft. \_\_\_\_\_ in.  
 Dock Height: \_\_\_\_\_ ft. \_\_\_\_\_ in.  
 Bumper Protection\*: \_\_\_\_\_ in.  
 (\*Includes bumper projection and any building wall/foundation offset or cantilever)

### TRUCKS AND TRAILERS SERVICED

Width: \_\_\_\_\_ Max. \_\_\_\_\_ Min.  
 Height: \_\_\_\_\_ Max. \_\_\_\_\_ Min.  
 Length: \_\_\_\_\_ Max. \_\_\_\_\_ Min.  
 Hydraulic Tailgate:  Yes  No  
 Rear Step Section:  Yes  No  
 Tailgate/Step Section Size: In.  
 Yard Jockeys:  Yes  No

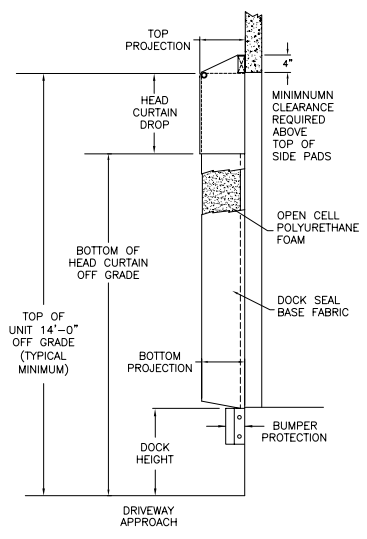
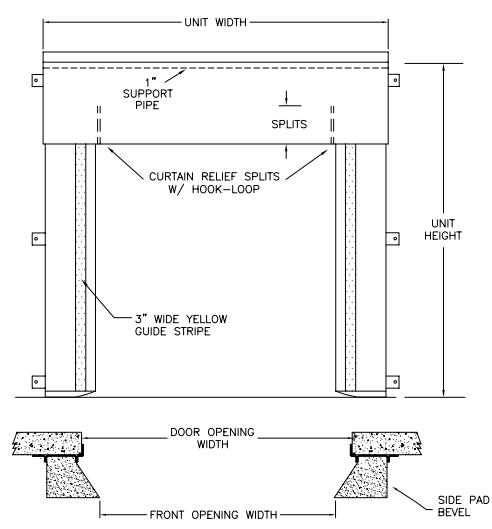

### QUANTITY \_\_\_\_\_

Model  DSH

Head Curtain Width (Distance to Outside of Side Pads) \_\_\_\_\_ (Total Inches)

Head Curtain Drop  18"  24"  30"  36"  42"  48"  \_\_\_\_\_

Head Curtain Splits  6"  12"  18"  24"  30"  36"  No Split

Head Curtain Options  None  Pull-Rope Assy  2" Foam Front  Sectional Foam Front

Side Pad Height \_\_\_\_\_ (Total Inches)

Side Pad Back/Face  12/12  6/10  8/12  10/12  10/15  8/15  12/15  10/18  6/14

Base Material  22 oz. Vinyl  40 oz. Vinyl  16 oz. CSM  40 oz. CSM  TS-55®

Color  Black  Tan  Brown  Blue  Green

Taper  Tapered  Non-Tapered

Top Projection  8"  10"  12"  14"  16"  18"  20"  22"  24"

Bottom Projection  8"  10"  12"  14"  16"  18"  20"  22"  24"

Bottom Flaps  None  3"  6"  Inside  Inside & Front  All 3 Sides  D Rings

Blockout  None  Top Projection \_\_\_\_\_"  Bottom Projection \_\_\_\_\_"

Wear Pleats  None  WP4  WP8  WP16  Side Pads  Head Pad Corners

Material  22 oz. Vinyl  40 oz. Vinyl  40 oz. CSM  TS-55®

Color  Black  Tan  Brown  Blue  Green

Wear Face  None  Head Pad  Side Pad

Material  22 oz. Vinyl  40 oz. Vinyl  40 oz. CSM  TS-55®

Color  Black  Tan  Brown  Blue  Green

Reinforced Inside Face  Standard  Side Pad Full Height

22 oz. Vinyl  40 oz. Vinyl  40 oz. CSM  XL-100™

Black  Tan  Brown  Blue  Green

Options  Door Numbers  Flame Retardant Fabric & Foam

Flame Retardant Fabric Only  Flame Retardant Foam Only

Side Pad Mounting Brackets  None  Flats & Angles  Angles  1 1/2" Offsets & Angles

\*Note: Consult factory for blockout application assistance.

\*Conversions: To convert measurements to metric, see formulas below:

Inches x 25.4 = millimeters (Example: 4" x 25.4 = 101.6 mm)

Feet x .3048 = meters (Example: 12' x .3048 = 3.66 m)